



Installation Instructions

Kit, Base Rail Bracket Part # 31565

Dealer / Installer:	Provide a copy of these Instructions to the end user of this product. These Instructions provide important operating and safety information for proper usage of this product. Demonstrate the proper use of the product with the end user. Have the end user demonstrate that they understand the proper use of the product.
End User:	Read and follow all instructions included in this manual. Ask your Dealer / Installer for assistance if you do not understand the proper use of the product. Never remove any decals from the product.

*APPLICATION: 2003 – 2006 Dodge Ram 1500, 2500 HD, 3500 HD P/U
(Excludes 3500 HD 4 X 4)*

NOTE: This bracket kit is to be used with the 31323 Bed Rail Kit.

Complete Parts List			
Item No.	Part No.	Description	Quantity
1	ERD10683	Driver Side Frame Bracket	1
2	ERD10684	Passenger Side Frame Bracket	1
3	ERD10344	Spacer Tube - Weldment	2
4	ERD10687	Tapped Plate - Weldment	2
5	ERD10029	1/2 -13 X 1-1/2" Wheel Bolt	4
6	ERD10676	5/8 -11 X 3-1/2" Hex Bolt	2
7	ERD10677	5/8 -11 X 5-1/2" Hex Bolt	2
8	ERD12184	5/8 -11 Hex Nut	4
9	ERD12189	1/2 -13 Serrated Lock Nut	4
10	ERD12188	5/8" Flat Washer	8
11	ERD12187	5/8" Lock Washer	4
12	ERD10031	3/4" Spacer Plate	4
13	ERD10030	Pull Wire for 1/2" Bolts	1
14	ERD10020	1/4" Spacer Plate	4
15	ERD10698	3/16" Spacer Plate	4

Caution: Do not install mounting rails over plastic bed liners. Plastic bed liners must be cut out of the way. Rails may be installed on spray in liners.

Note: Consult spray liner installer for recommended curing time.

Tools Required	
3/4" Socket/Wrench	17/32" Drill Bit
15/16" Socket/Wrench	5/8" Drill Bit
Drill	Torque Wrench

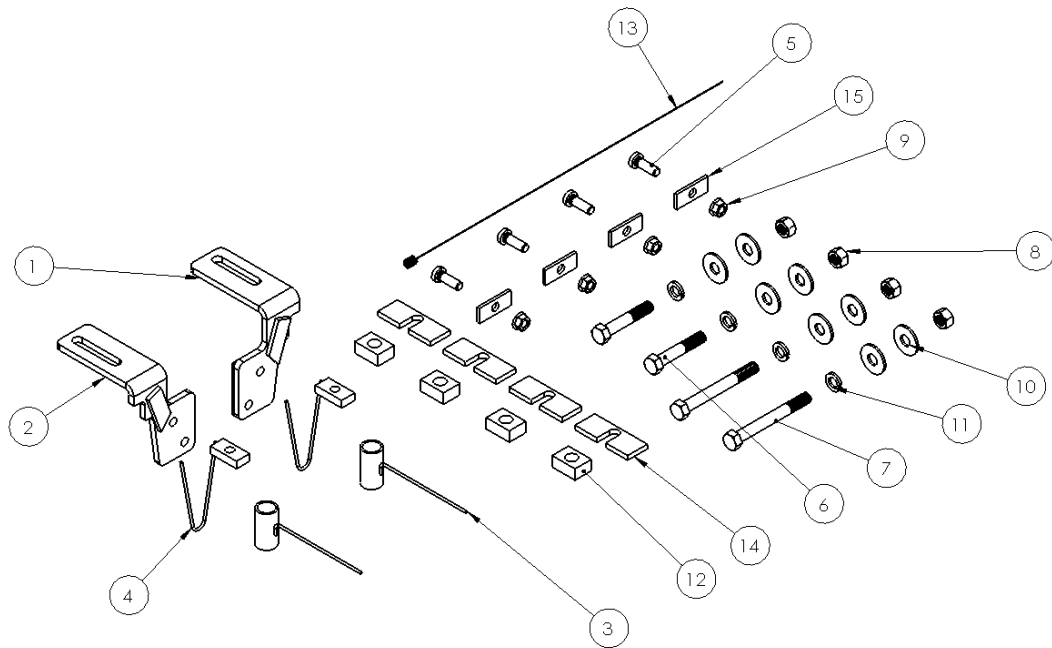

1. Place the two bed rails across the truck bed between the wheel wells. Position the 5th wheel uprights between the bed rails so that the tabs in the base of each upright will fit into the slots in the ends of the bed rails. Secure uprights in place with the rail hitch pins and hair pins supplied with the 5th wheel installation kit. Securely attach 5th wheel cross member to uprights.

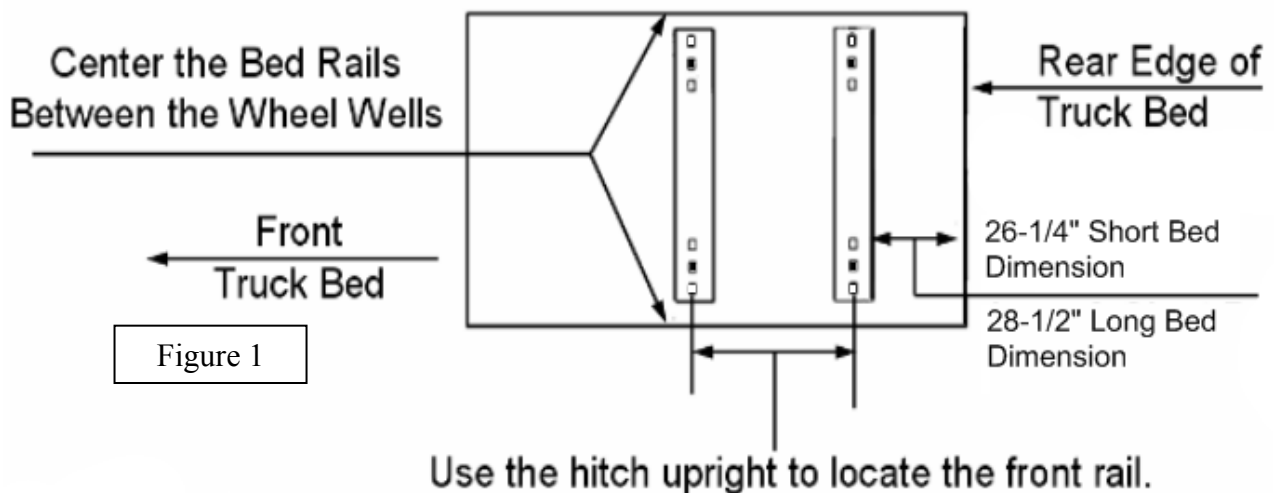

2. Position the bed rail assembly in truck bed as shown on the Figure 1. When hitch is correctly positioned in the bed and the bed rails are parallel, mark four attachment points on the truck bed using the slots indicated on the layout in Figure 1.
NOTE: Mark to outer edge of the forward slots. Check below the bed before drilling holes to see that all wiring, brake lines or other obstructions are moved out of the way and will not be contacted by the drill. Move the hitch assembly out of the way and drill four 5/8" diameter attachment holes down through the bed at the previously marked points. Be certain that the forward holes are drilled in correct location. They must also be drilled through top of truck boxed frame.

3. Reposition the bed rails in the bed so that the square 5/8" hole in each rail is lined up over the drilled holes. Place a 3/4" thick spacer plate (#12) under ends of each bed rail, in line with the drilled holes, as shown on Figure 2.

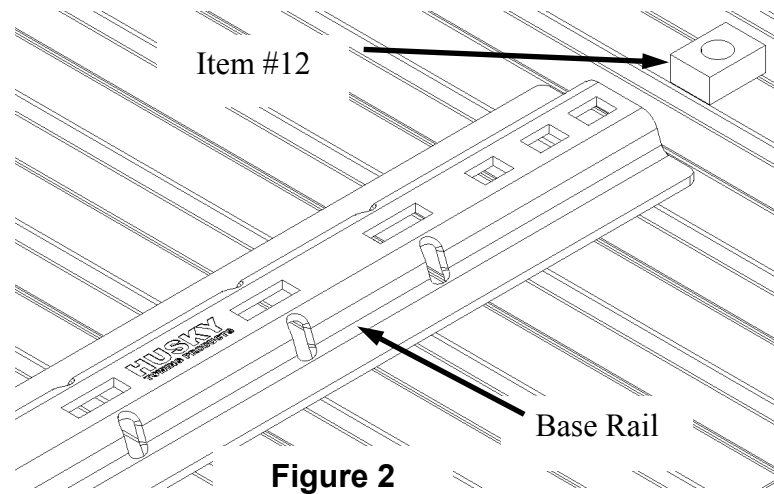

4. If the bed corrugation above the angle bracket is UP, leaving a space above the angle bracket, place a spacer plate (#14) in this location as shown on Figure 3. If the corrugation is DOWN, at this location, place a spacer plate (#14) in the bed, under the base rail as shown on Figure 3. Bolt parts loosely in place as shown in Figure 3a.

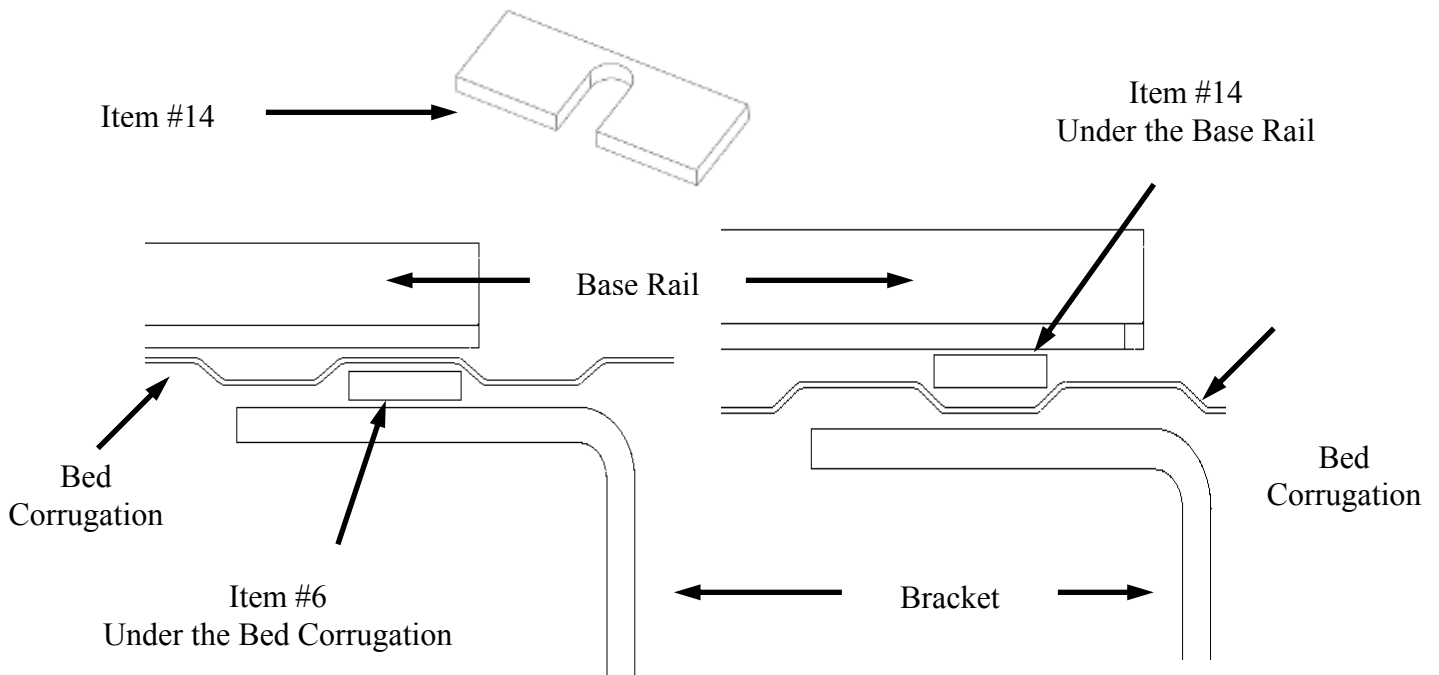
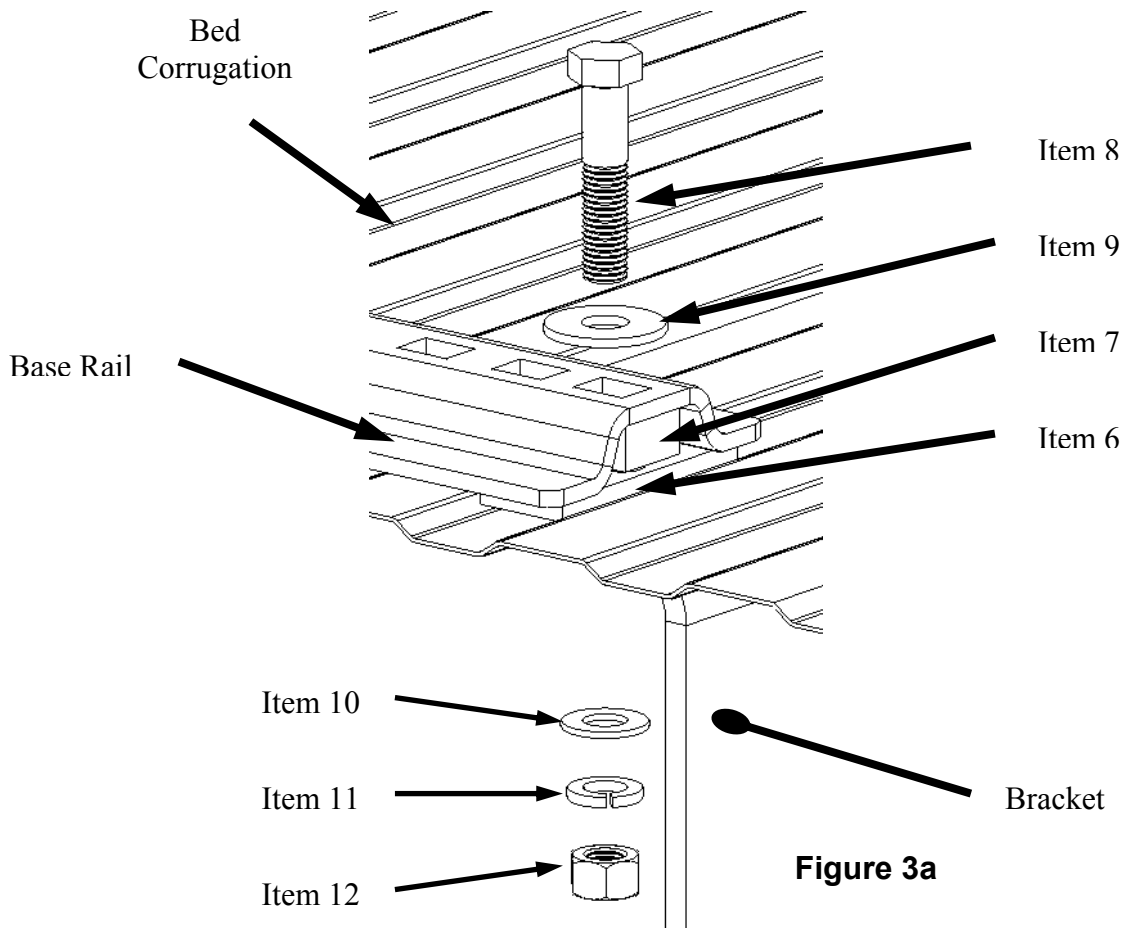
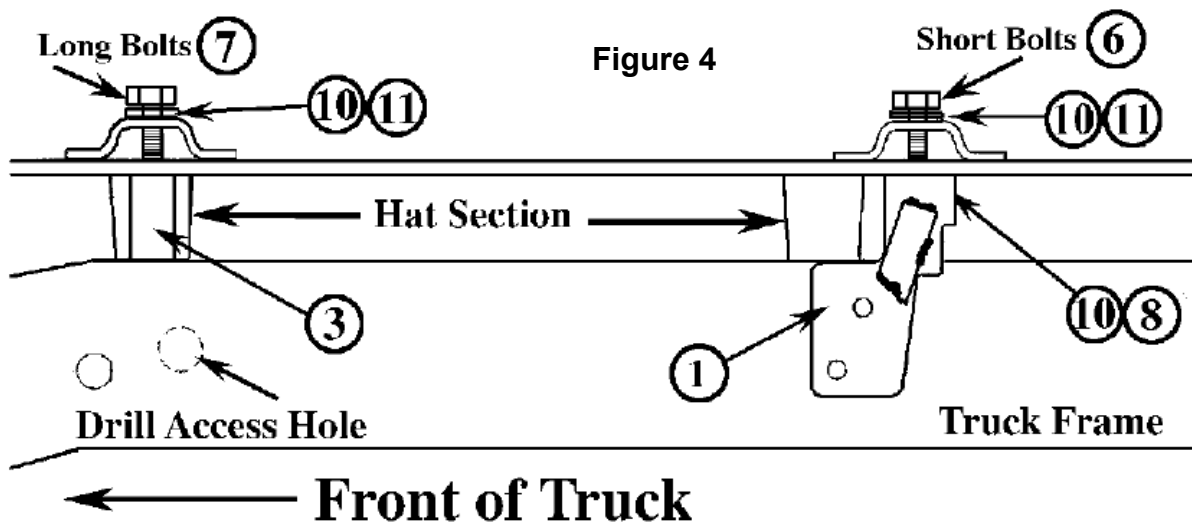

Figure 3



- Position the left bracket (#1) and right bracket (#2), under the bed, at the rear attachment and align with the 5/8" holes drilled down through the bed. See Figure #4 for bracket location details. Push the installed frame brackets tight against the flat side of the truck frame and underneath surface of truck bed. Drop the 5/8" bolts down through the rear bed rail, drilled holes in bed and frame brackets. Bolt loosely in place.
NOTE: There are two lengths of 5/8" bolts. Use the shorter hex bolts at the rear frame bracket attachments. Securely bolt the rear base rail in place. Be sure frame brackets are tight against the side of truck frame. Tighten the 5/8" bolts to 150 ft.-lbs. torque.



- Slide tube spacers (#3) into the forward under bed hat section from the open end in each wheel well. See Figure 5.

NOTE: On some applications a small filler panel may appear to obstruct placement of the spacer tube. This filler panel can be modified to gain access to the hat section. See detail for this procedure on Figure 6. Align the tube spacers with the drilled holes and drop the long 5/8" bolts (#7) down through all parts and top of frame. See Figure 5.

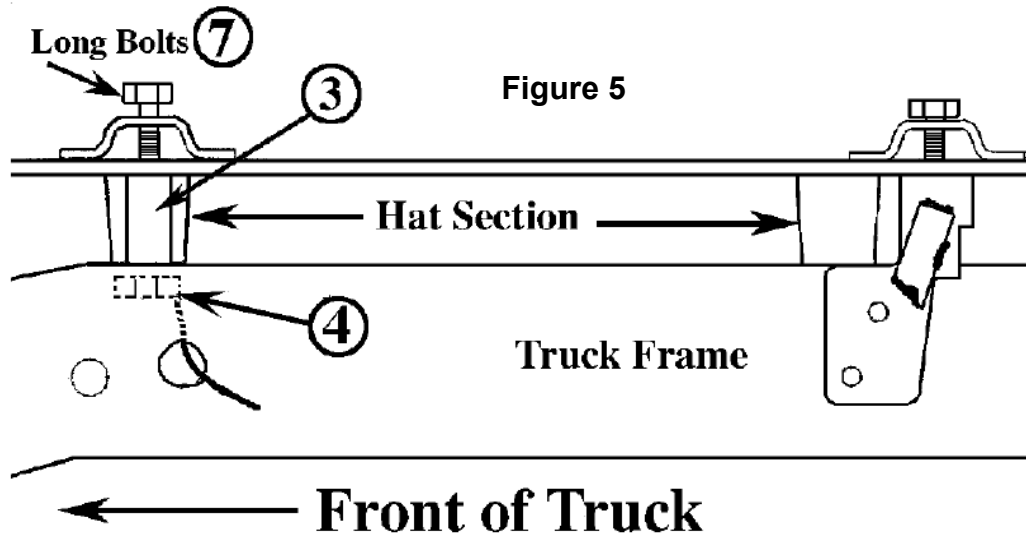

Make two 3/4" cuts in sheet metal panel as shown. Bend flap outward and up to insert tube spacer. Bend flap down after installation is complete. Cut areas may be covered with paint or undercoating.

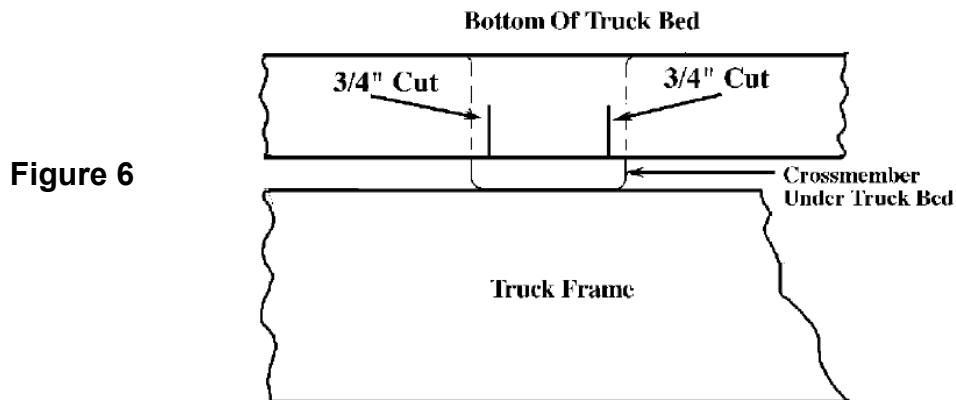

- On some vehicles there will be an access hole in the bottom of the truck frame, near the front attachment point. If there is no access hole in frame, drill a 1-1/4" diameter access hole in the side of the frame at the location shown on Figure 4. Using the access hole, insert the tapped plate (#4), with wire handle, into the truck frame and align with 5/8" bolt coming down from bed location, as shown on Figure 5. Tighten the 5/8" bolts to 150 ft-lbs. torque.
- Each of the angle brackets must be attached to the side frame of the truck with two special 1/2" wheel bolts (#5). Drill two 17/32" holes through the side of the truck frame using two of the holes in each frame bracket as guides.

CAUTION: Holes MUST be drilled 17/32" diameter, so that the special wheel bolts will seat properly. If holes are too small, the bolt may break. If holes are too large, the bolt will not grip properly.

9. Thread the coiled end of the pull wire (#13) through one of the drilled 17/32" diameter holes and angle it towards the rear of the frame. There are pre-existing holes/slots that that should be large enough to pull the spacer plate (#15) and the wheel bolt (#5) through using the pull wire. Determine which of these existing holes to use by fitting the spacer plate (#15) into. Continue to feed the pull wire through the desired hole/slot far enough so you can then feed the pull wire through the spacer plate and then thread the wheel bolt into the coil of the pull wire.
10. Carefully pull the straight end of the pull wire out of the frame and also guide the spacer plate into the hole/slot first and then the wheel bolt, see Figure 8. Continue to pull the pull wire until you can pull the threaded end of the wheel bolt out of the 17/32" diameter hole, see Figure 7. Hold the wheel bolt and un-screw the pull wire from it and then thread the lock nut onto the wheel bolt. Repeat steps 9 and 10 for each of the other spacer plates and wheel bolts.

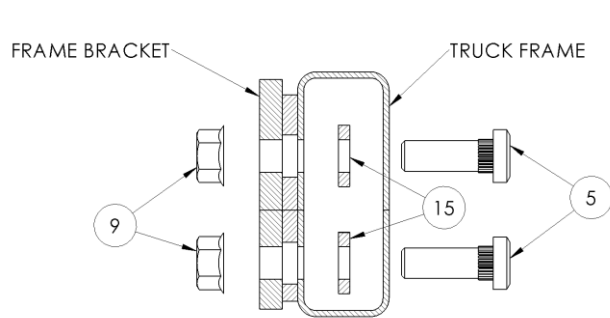

Figure 7

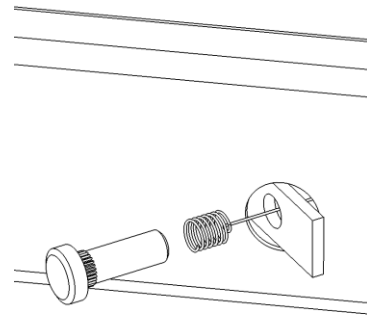

Figure 8

11. Tighten all 1/2" attachment bolts to 75 ft.-lbs.
12. Check each rail hitch pin for freedom of movement in the bed rail connection before tightening the 5/8" carriage bolts. Adjust uprights, if necessary, by placing a washer between the upright and the cross member to obtain free pin movement. See Figure 9.

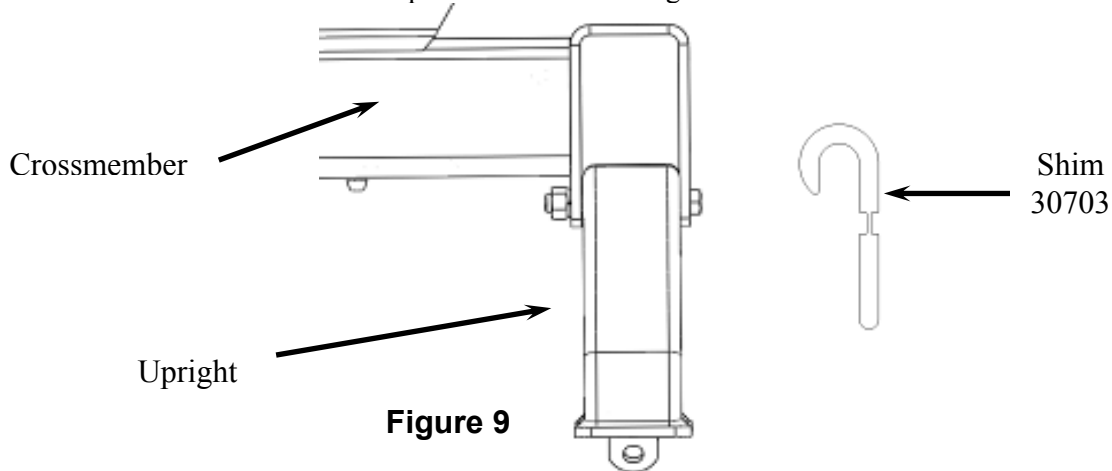

Figure 9

9. Tighten the 5/8" bolts to 125–160 ft – lbs torque. Failure to tighten bolts as described may result in fastener loss or failure.

TORQUE VALUE CHART	
Bolt Size	Torque Range (ft.-lbs.)
1/2"	65-85
9/16"	100-120
5/8"	125-160
3/4"	240-280