



Installation Instructions

Kit, Base Rail Bracket Part # 31415

Dealer / Installer: Provide a copy of these Instructions to the end user of this product. These Instructions provide important operating and safety information for proper usage of this product. Demonstrate the proper use of the product with the end user. Have the end user demonstrate that they understand the proper use of the product.

End User: Read and follow all instructions included in this manual. Ask your Dealer / Installer for assistance if you do not understand the proper use of the product. Never remove any decals from the product.

APPLICATION: 1999 – 2006 Classic Chevrolet & GMC Silverado & Sierra 1500 & 2500 Light-Duty Pick-ups
 1999 – 2007 Classic Chevrolet & GMC Silverado & Sierra 2500 & 3500 Pick-ups
 2007 – 2010 New Body Style Chevrolet & GMC Silverado & Sierra 2500 & 3500 Heavy-Duty Pick-ups (w/ integrated Electric Brake Control)

NOTE: This bracket kit is to be used with the 31323 4 Bolt Bed Rail Kit or 30686 10 Bolt Bed Rail Kit.

Complete Parts List		
Item No.	Description	Quantity
1	Bracket, Angle	2
2	Bracket "L" long	2
3	Plate, Spacer	4
4	Bolt, Wheel 1/2 -13 X 1-1/2"	8
5	Lock Nut Serrated 1/2 -13	8
6	Bolt, Carriage 5/8 -11 X 3"	2
7	Bolt, Carriage 5/8 -11 X 3-1/2"	2
8	Washer, Flat (5/8")	4
9	Washer, Lock (5/8")	4
10	Nut, Hex (5/8 -11)	4
11	Spacer Tube (1")	4
12	Pull Wire (1/2")	1

This kit may contain either one of the spacers (item 11) shown below.

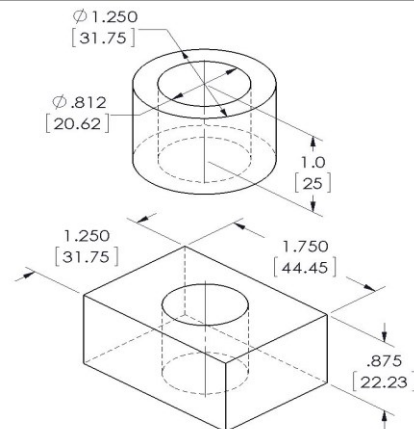

Tools Required
3/4" Socket & Wrench
15/16" Socket & Wrench
5/8" Drill Bit
17/32" Drill Bit
Torque Wrench
Safety Glasses

Caution: Do not install mounting rails over plastic bed liners. Plastic bed liners must be cut out of the way. Rails may be installed on spray in liners.

Note: Consult spray liner installer for recommended curing time.

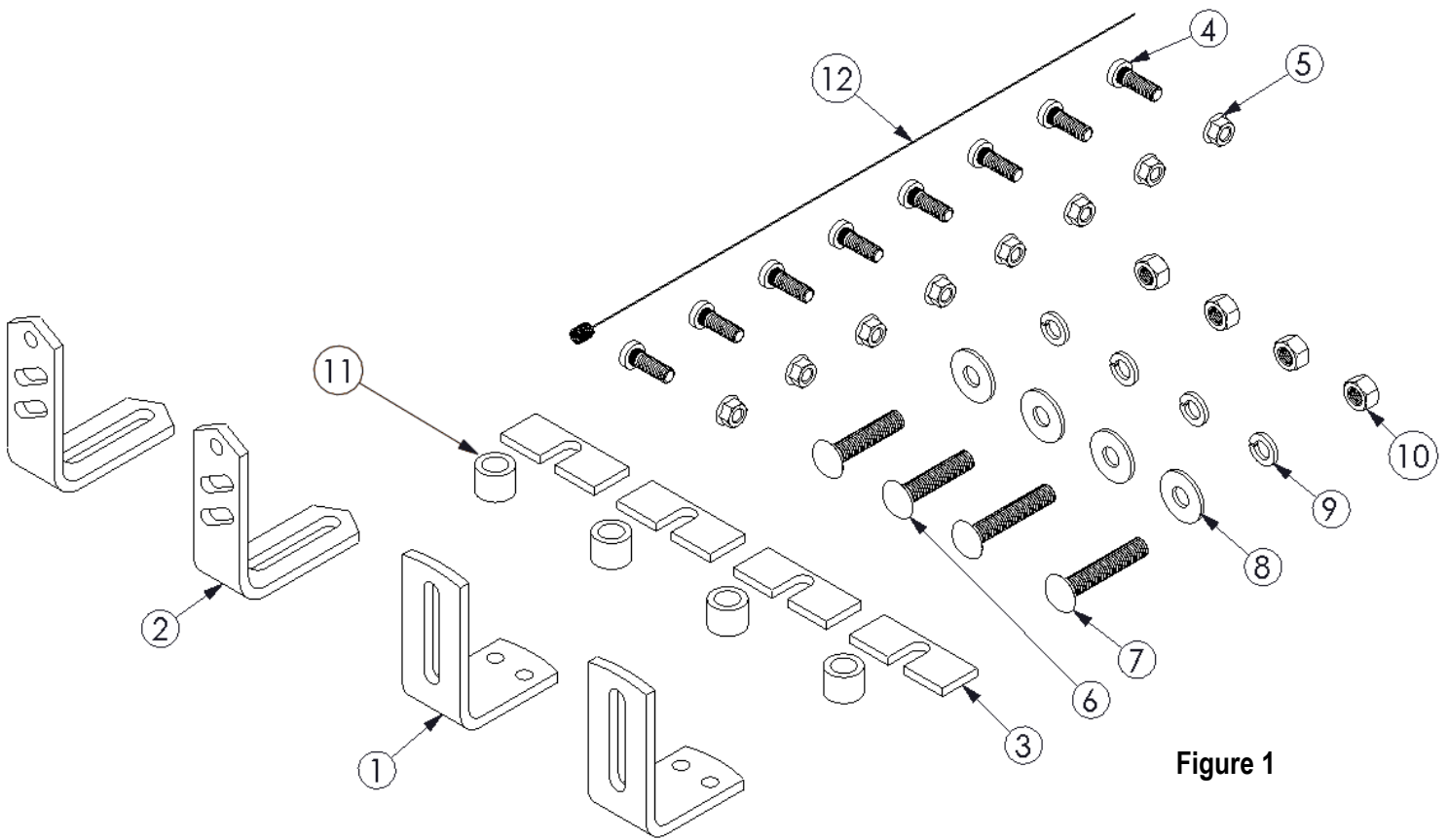
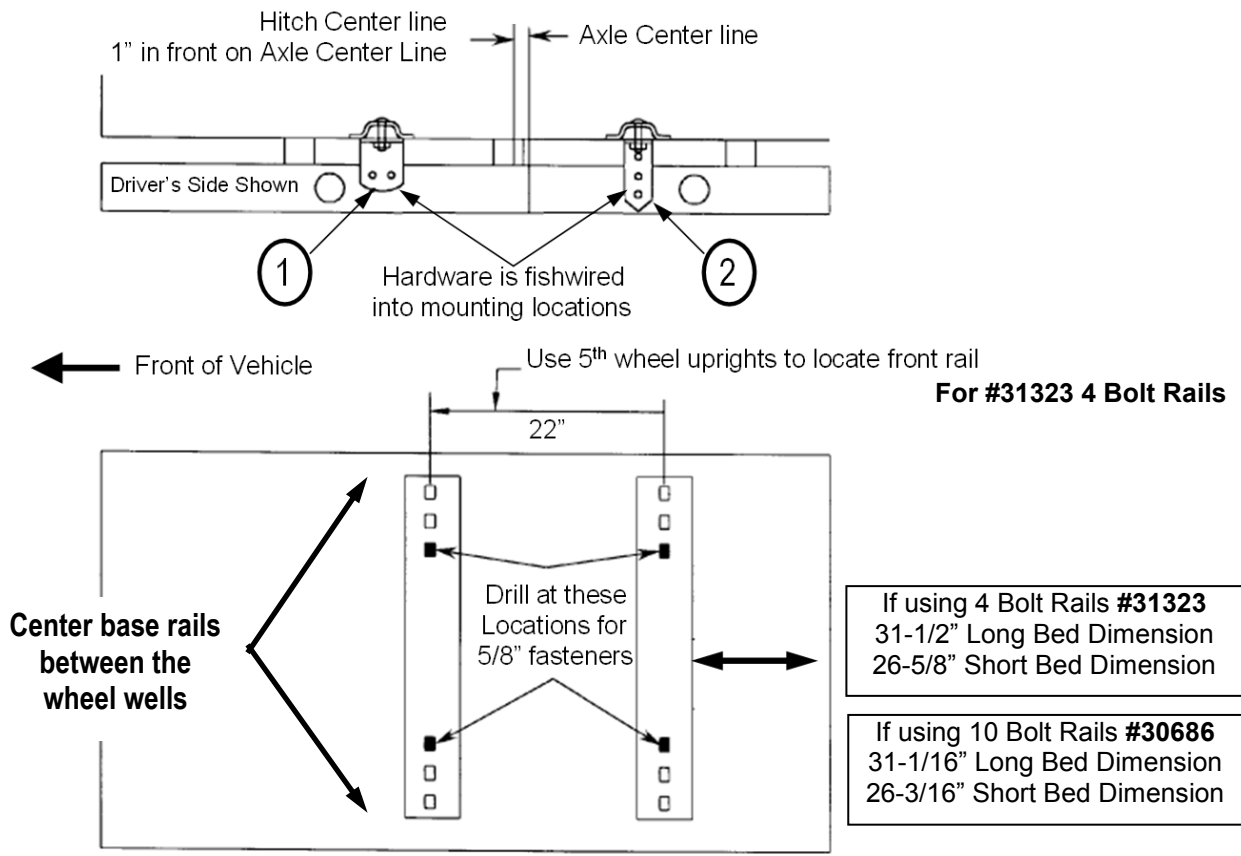

Figure 1



Note: Check cab clearance requirements before installing the hitch.
The distance from the cab to the hitch center line is approximately 56" for 8' truck beds & 43" for 6.5' truck beds

Figure 2

1. Place two base rails across the truck bed between the wheel wells. Position the 5th wheel uprights between the bed rails so that the tabs in the base of each upright will fit into the slots in the ends of the bed rails. Secure the uprights in place with the rail hitch pins and hair pins supplied with the 5th wheel installation kit. Securely attach 5th wheel cross member to uprights.
2. Position the bed rail assembly in truck bed as shown on Figure 2. When hitch is correctly positioned in the bed and the bed rails are parallel, mark four attachment points on the truck bed using 5/8" square holes indicated on the layout Figure shown above. Check below the bed before drilling holes to see that all wiring, brake lines or other obstructions are moved out of the way and will not be contacted by the drill. Move the hitch assembly out of the way and drill four 5/8" diameter attachment holes down through the bed at the previously marked points in Figure 2.
3. Reposition the bed rails in the bed so that the square 5/8" hole in the end of each rail is lined up over the drilled holes. Place a 1" thick spacer tube (#10) under ends of each bed rail, in line with drilled holes. See Figure 3.

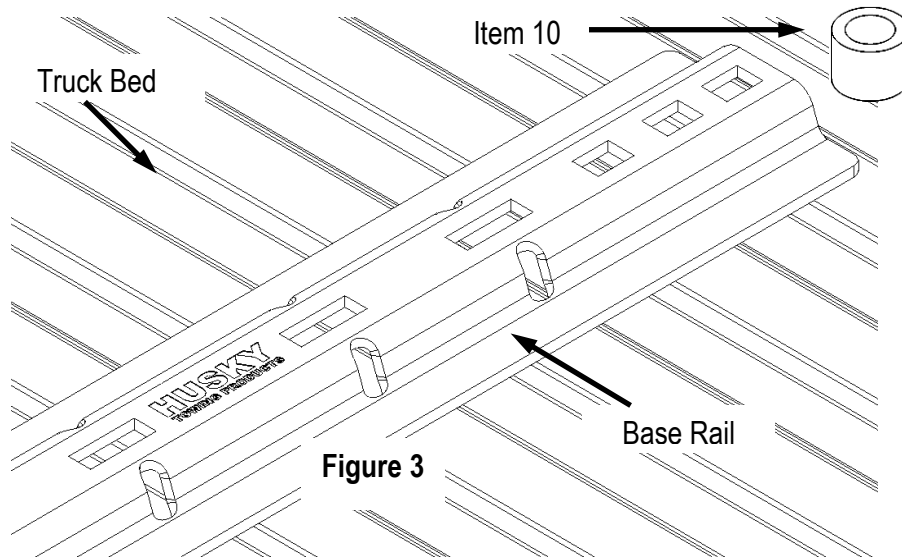

4. If the bed corrugation above the angle bracket is UP, leaving a space above the angle bracket, place a spacer plate (#3) in this location as shown on Figure 2. If the corrugation is DOWN, at this location, place a spacer plate (#3) in the bed, under the base rail as shown on Figure 4. Bolt parts loosely in place as shown in Figure 4.
5. Position the short angle brackets under the bed, at the forward attachment and align with the 5/8" carriage bolts protruding down through the bed. Use long angle brackets at the rear attachments. See Figure 2 on page 2 for details of bracket location.

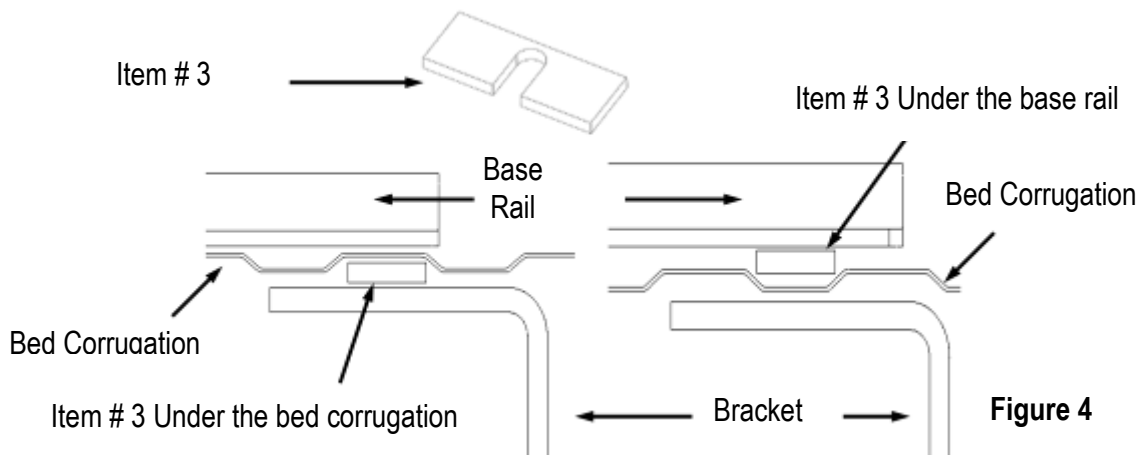

6. Move the installed angle brackets so that they rest tightly against the flat side of the truck frame and underneath surface of truck bed. Drop the 5/8" bolts down through bed rails and angle bracket.
Note: There are 2 lengths of 5/8" carriage bolts included in the kit. Use the shorter on applications where vehicle clearance may be close to the attachment point. The bolts can be used in any attachment location.
7. Before drilling any holes, check inside the frame to be sure that there are no wires, brake lines or other obstructions in the frame which may be contacted by the drill. Each of the angle brackets must be attached to the side frame of the truck with two special 1/2" wheel bolts. Drill two 17/32" holes through the side of the truck frame using two of the holes in each angle bracket as guides. See Figure 5.
CAUTION: Holes **MUST** be drilled 17/32" diameter, so that the special wheel bolts will seat properly. If holes are too small, the bolt may break. If holes are too large, the bolt will not grip properly.

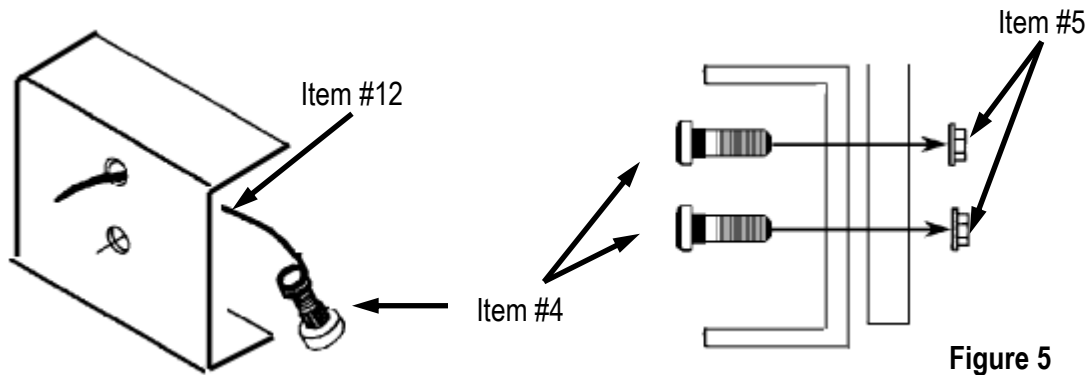

8. Place the wheel bolts into the frame first and then out through the angle brackets. See Figure 5. Some applications will require the use of a pull wire to align the bolts into the drilled holes in the frame. Thread the pull wire coil over the end of the wheel bolt and pull through frame and angle bracket. See Figure 5. Secure each bracket to the truck frame. The knurled portion of the bolts will lock into the frame holes as the nuts are tightened. Use of an air wrench will make installation much better.

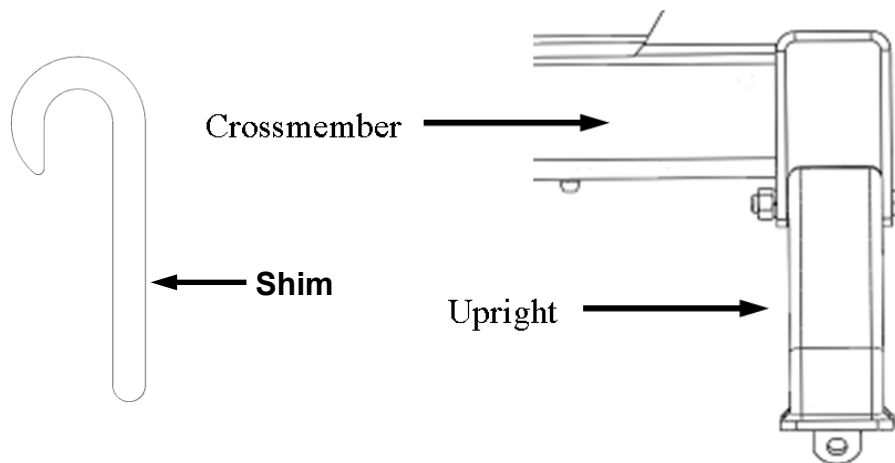

9. Tighten all 1/2" attachment bolts to 75 ft.-lbs. torque.
10. Check each rail hitch pin for freedom of movement in the bed rail connection before tightening the 5/8" carriage bolts. Adjust uprights, if necessary, by placing shim 31582 or 30243 between the upright and the cross member to obtain free pin movement. See Figure 6. Shims 31582 & 30243 sold separately.
11. Tighten each 5/8" bed rail attachment bolt to 150 ft.-lbs. torque. Failure to tighten bolts as described may result in fastener loss or failure.